

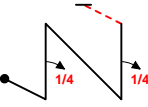



INTERNATIONAL AEROBATIC CLUB SCORESHEET

A

Contest: U.S. National Championships	Date: 2014	Category: Intermediate	Programme: Unknown	pilot's number	
--	----------------------	----------------------------------	------------------------------	----------------	--

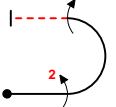
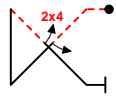
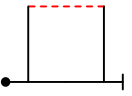
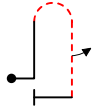
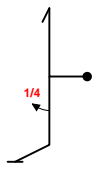
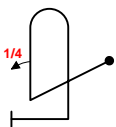
No	Symbol	Catalogue No.	K	Total K	Grade	Remarks
1		1.3.14.1 9.1.1.1 9.1.1.1	22 6 6	34		
2		1.1.7.4 9.1.5.1	9 2	11		
3		7.2.1.1 9.2.3.4 9.1.3.4	6 9 8	23		
4		1.3.4.4 9.1.4.2 9.4.4.2	18 4 5	27		
5		7.4.3.1	14	14		
6		8.4.3.1 9.1.5.2	15 4	19		
7		5.2.1.1 9.1.5.1	17 2	19		
8		8.4.1.1 9.1.1.1	13 6	19		
9		1.1.7.1	9	9		

Presentation	8	
---------------------	----------	--

FIGURE TOTAL K = 175

INCLUDING PRESENTATION = 183

Aircraft Type:

FREE PROGRAM CHECKED BY:

Signature:	Printed Name:	Date:
IAC No.		

Judge Name:

IAC#

Assistant Name:

IAC#



pilot



B	Contest: U.S. National Championships	Category: Intermediate
Date: 2014	Program: Unknown	Pilot's No. <input type="text"/>

wind direction

Pilot:

NOTE CROSS-BOX START

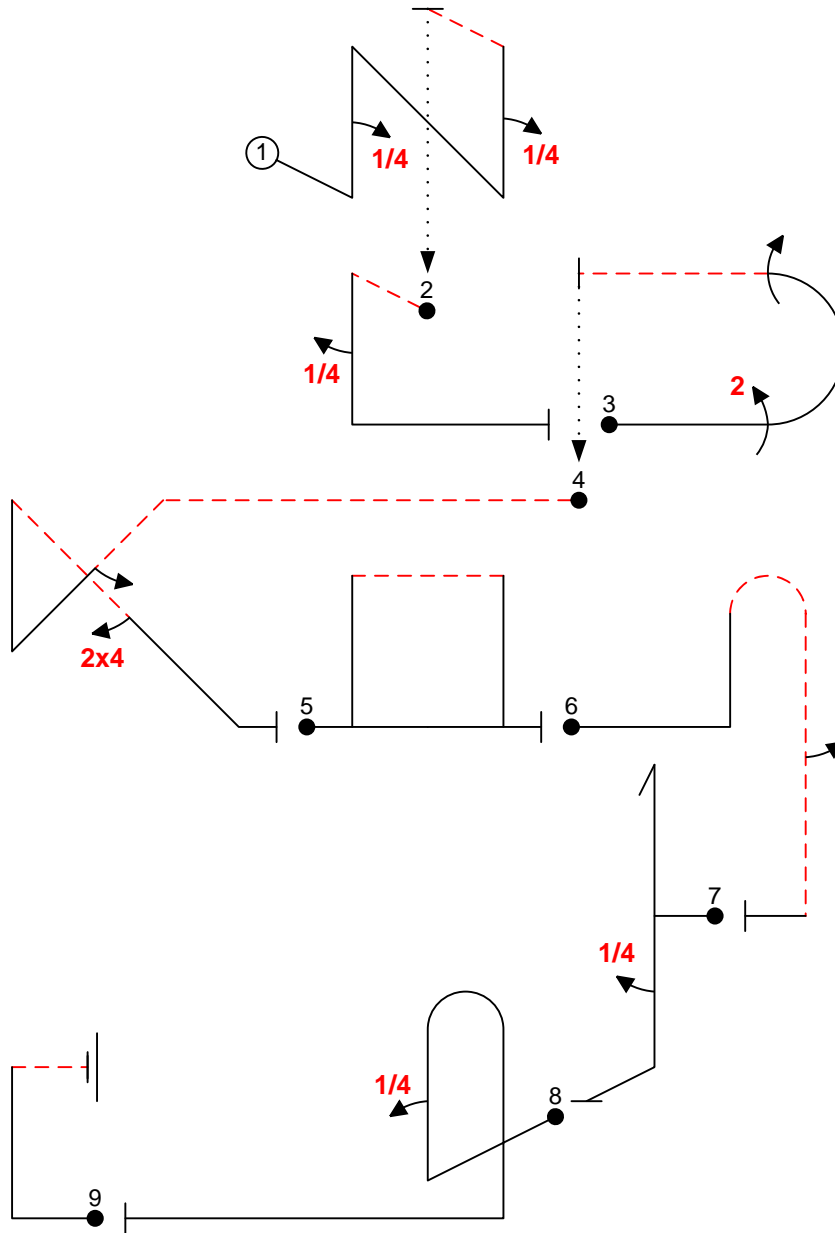

A/C:

(signature/date)

FREE PROGRAM CHECK BY:



C	Contest: U.S. National Championships	Category: Intermediate
Date: 2014	Program: Unknown	Pilot's No. <input type="text"/>

wind direction

NOTE CROSS-BOX START

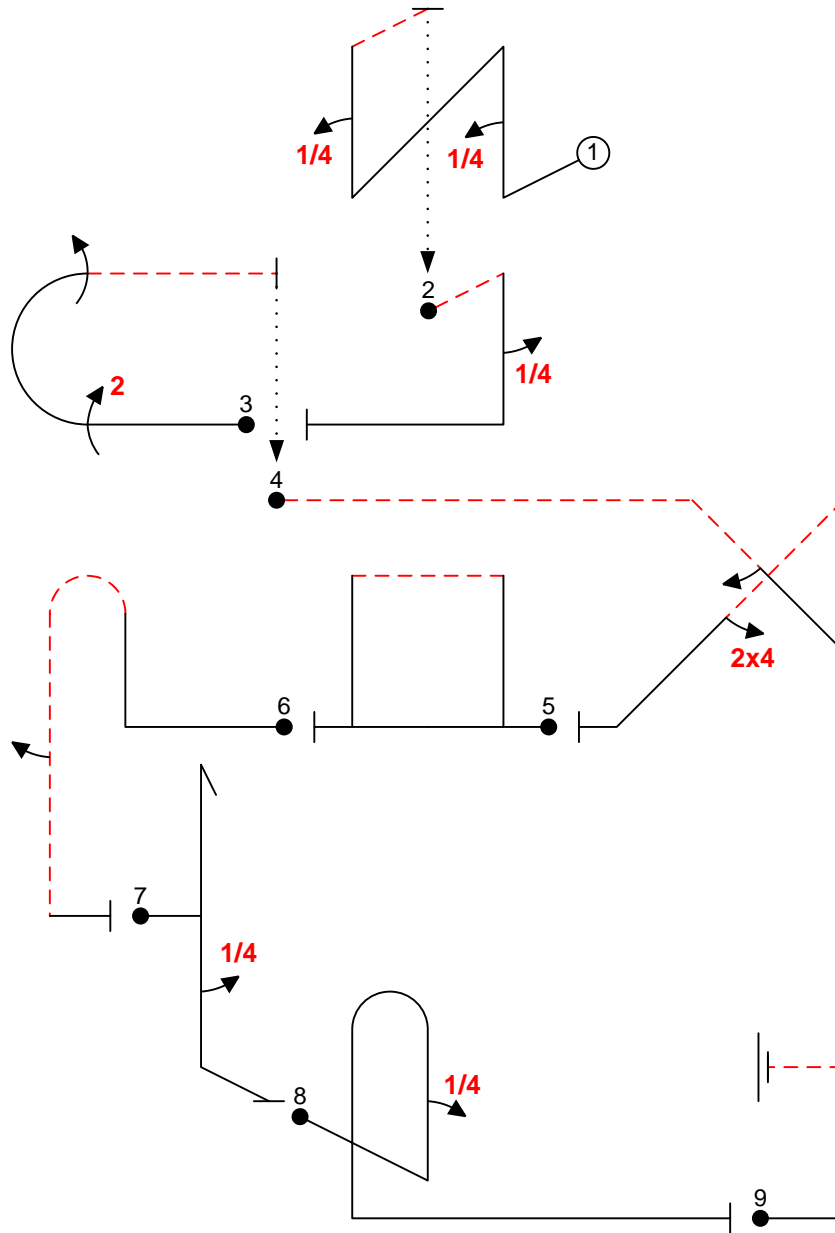

Pilot:

A/C:

(signature/date)

FREE PROGRAM CHECK BY: